

TOYOTA

SIENNA

2016

FOG LIGHT

Part Number: 00016-08401

Accessory Code: LF1000



**Conflicts**

- Factory Fog Lights, Previous Model Years.
---

**Kit Contents**

Item #	Quantity Req'd.	Description
1	2	Fog Lamps
2	2	Fog Lamp's bezels
3	1	Switch Assembly
4	1	Fog light operation guide

**Hardware Bag Contents**

Item #	Quantity Req'd.	Description
1	1	Wire harness
2	1	Switch harness
3	2	Relays
4	15	Wire ties
5	2	Phillip head screws
6	2	Black T-Taps

**Additional Items Required For Installation**

Item #	Quantity Req'd.	Description

**Recommended Tools**

<b>Safety Tools</b>	
Safety Glasses	
Electrical Tape	
<b>Installation Tools</b>	
10mm Wrench	
Phillips Screw Driver	
Pliers	
Side Cutters	
Torque wrench	48 in-lbs
<b>Special Chemicals</b>	
3M Silicon Sealant	

**Color Applicability/Trim Level**

Service Part	Fog Light Housing RH	Fog Light Housing LH	Switch	Wire Harness	Relay Kit	Bezel LH	Bezel RH
Part Number							
00016-08401-03	X						
00016-08401-04		X					
00016-32230-02			X				
00016-32230-01				X			
00016-32105-04					X		
00016-08401-02						X	
00016-08401-01							X

**General Applicability**

2016 models only, 5328, 5338, 5366
------------------------------------







**Recommended Sequence of Application**

Item #	Accessory
1	
2	
3	

Mandatory

Legend

**Legend**

-  **STOP:** Damage to the vehicle may occur. Do not proceed until process has been complied with.
-  **OPERATOR SAFETY:** Use caution to avoid risk of injury.
-  **CAUTION:** A process that must be carefully observed in order to reduce the risk of damage to the accessory/vehicle and to ensure a quality installation.
-  **TOOLS & EQUIPMENT:** Used in Figures calls out the specific tools and equipment recommended for this process.
-  **REVISION MARK:** This mark highlights a change in installation with respect to previous issue.
-  **SAFETY TORQUE:** This mark indicates that torque is related to safety.

**SPECIAL NOTE: Installation Sequences**

After TMS and Safety mandated preparatory steps have been taken, the installation sequence is the suggested method for completing the accessory installation. In some instances the suggested sequence is written for one associate to install and in others the sequence is given as part of a team accessory installation. Unless otherwise stated in the document, the associates may perform the installation steps in any order to make the installation as efficient as possible while maintaining consistent quality.

Care must be taken when installing this accessory to ensure damage does not occur to the vehicle. The installation of this accessory should follow approved guidelines to ensure quality installation. These guidelines can be found in the Accessory Installation Practices document.

This document covers such items as:

- Vehicle Protection (use of covers and blankets, cleaning chemicals, etc)
- Safety (eye protection)
- Vehicle Disassembly / Reassembly (panel removal, part storage, etc)

## Preparation



Remove negative battery cable. Optional step: remove battery from vehicle.

## Installation

1. Remove battery tray. Secure the relay and fuse to negative battery cable. Secure top and bottom with wire ties (picture 1).

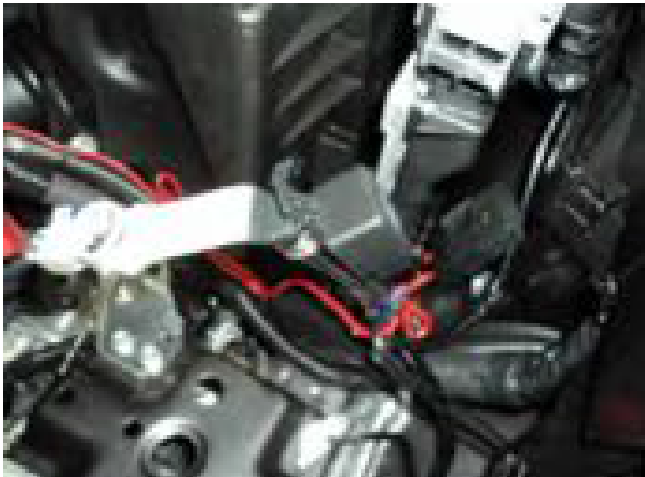

Picture 1

2. Attach the ring terminal with 2 black wires to the 10mm ground bolt below the battery (picture 2)

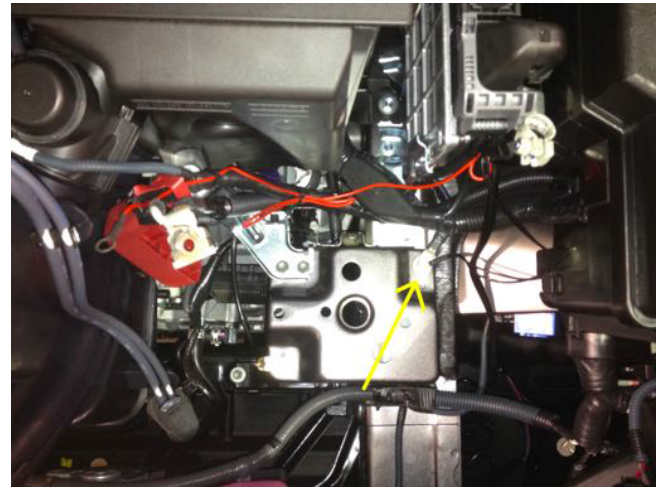

Picture 2

3. Connect the ring terminal from the relay (12v red wire) routing it through positive red terminal cover (picture 3)



Picture 3



Note: If removing the 12mm nut from the positive or negative terminal junction. When re-tightening the torque specification is 67in lbs.

4. Route wire to large vehicle grommet and secure with wire 3 wire ties (picture 4)

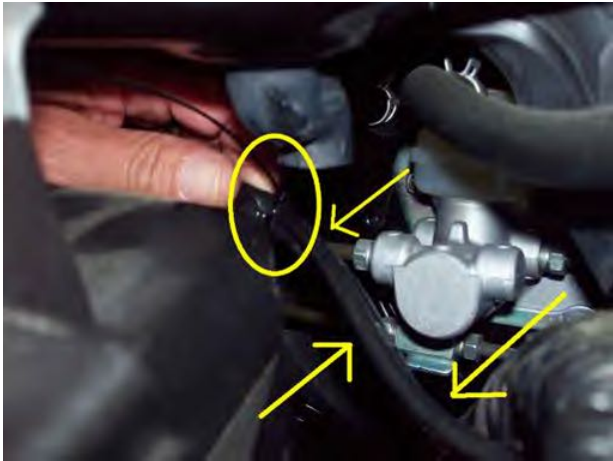

Picture 4

5. Locate the large vehicle harness grommet on the left side. If accessible, cut the auxiliary wiring access nipple off the grommet or cut 1/4" slit in grommet. Secure excess wires with wire ties to fuse block wire harness. Push the red and gray/white wires through firewall. Note: Extra caution should be taken not to damage the bullet connectors. Seal with 3M Silicone sealant (picture 5)

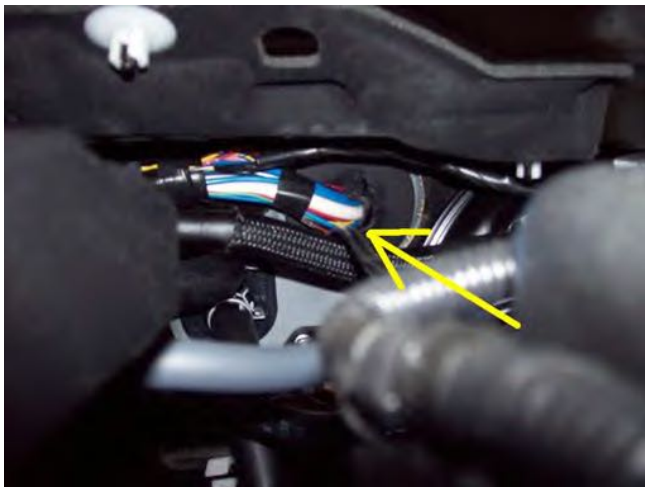

Picture 5

**Vehicle Disassembly**

6. Remove driver side door scuff plate. Disengage with panel tool and remove (picture 6 and 6A)

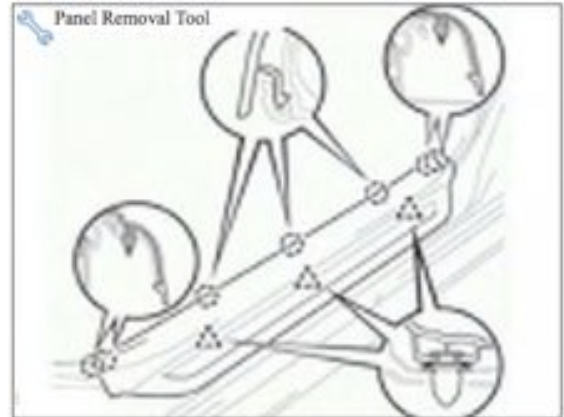

Picture 6



Picture 6A

- a. Remove the driver side cowl side trim (picture 6). Unscrew the cowl side trim clip. Disengage two (2) clips and remove the cowl side trim (picture 7)

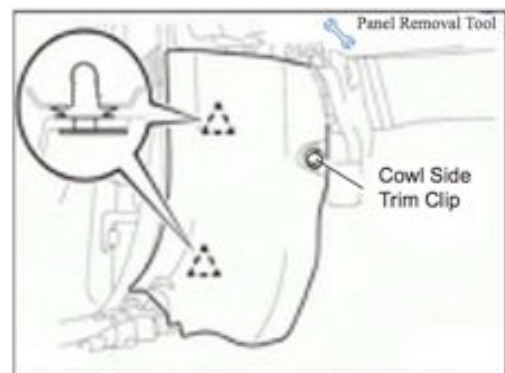

Picture 7

- 7. Remove the finish panel covering the knee airbag (picture 8)



Picture 8

- 8. Remove the lower finish panel (picture 9)



Picture 9

- 9. Remove hood latch and gas door cables (see picture 10)

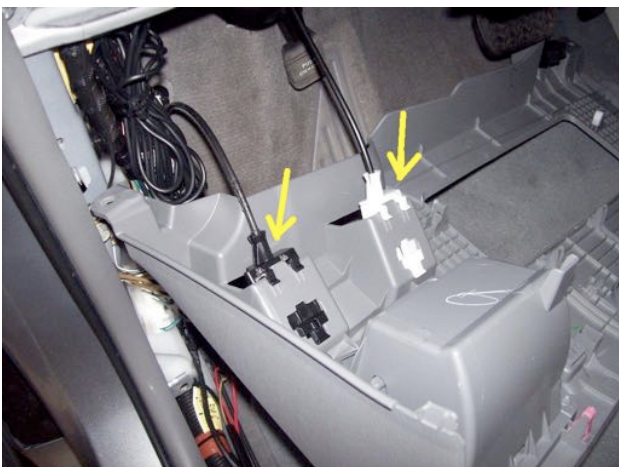

Picture 10

- 10. Remove switch panel left of steering wheel (picture 11)



Picture 11

- 11. Remove far right dash panel switch plug
- 12. Install switch into switch knockout (pic. 12)



Picture 12

- 13. From inside the cabin, locate the wires that were pushed through in step 5. It will be the grommet above the gas pedal (picture 13)



Picture 13

14. Install a black T-tap to connector 2F pin 35, gray wire. Connector 2F is located by the main junction block (pictures 15, 15A, 15B & 16). Then connect the green/black wire from fog light harness.
15. Install a black T-tap to connector 2F pin 25, light green wire (pictures 15, 15A, 15B & 16). Then connect the orange/black wire from fog light harness .

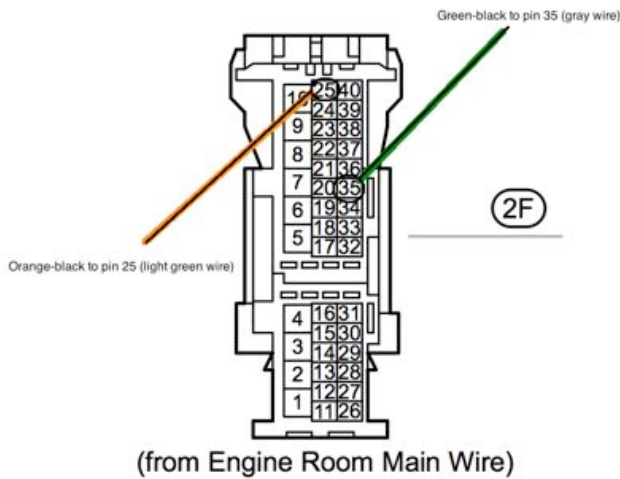

Picture 15

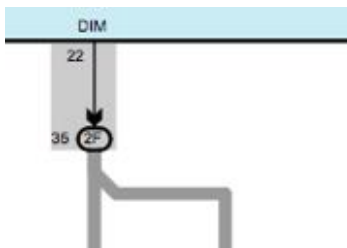

Picture 15A: High Beam to connector 2F, pin 35, gray wire

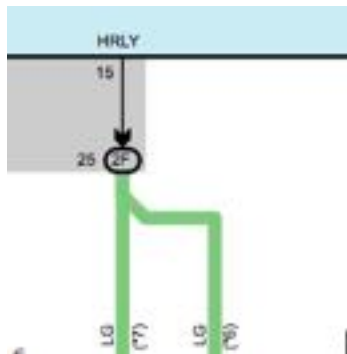

Picture 15B: Low beam to connector 2F, pin 25, light green wire



Picture 16

16. Secure fog light wire and relay with wire ties. Run wire to switch location on finish panel and secure any excess wire with wire ties (picture 17)



Picture 17

17. Connect switch harness to switch
18. Reinstall dash panels and reconnect cables

**ENGINE COMPARTMENT**

19. Drop fog light harness down on left side of vehicle
20. Loosen part of lower splash shield with 6x10mm bolts and 4 push pins and remove fog light cover plates (picture 18)



Picture 18

21. Insert one side of the fog light into the plastic sleeve and secure other side with supplied Phillip screws (see picture 19). Repeat this step for left and right fog lamps

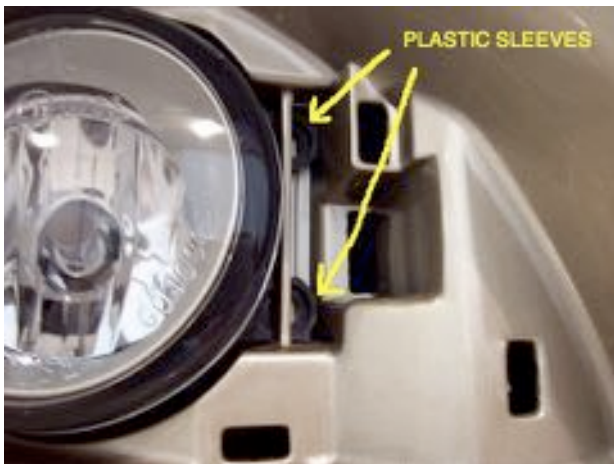

Picture 19



**NOTE:** Use only hand tools to adjust the fog light aiming screw. DO NOT use automatic tools, as they will damage the fog light

22. Plug in left side fog light into harness plug and secure with wire ties
23. Run harness to right fog light and secure with 3 wire ties (picture 20)

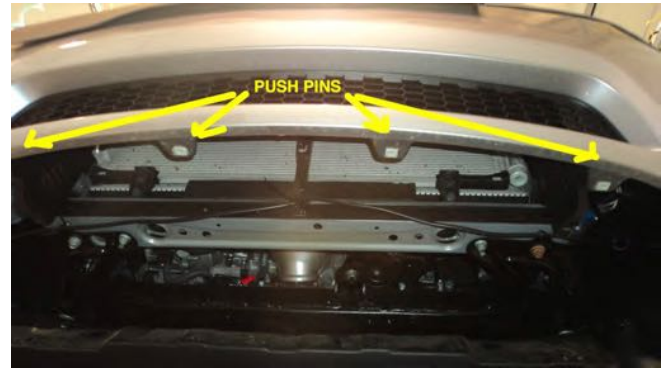

Picture 20

24. Plug in right fog light harness into fog light
25. Snap on both fog light bezels
26. Reinstall lower splash shield
27. Reinstall battery bracket & assembly. If applicable reconnect battery negative terminals at 48 in-lb. Reconnect battery assembly.



**Checklist** – these points MUST be checked to ensure quality installation**Check System for Operation**

1. Turn on headlamp low beams, then press fog light switch to “ON” position. Fog lights should be working. Fog lights will only work when the low beam headlamps are “ON”. Fog lights will NOT work when the high beam headlamps are “ON”

**Fog Light Aiming**

Traditional fog lights are usually mounted in the front bumper about 10-24 inches from the ground. There are two important issues to address when installing fog lights: the first is to minimize the amount of return glare into the drivers eyes, and the other is to minimize the glare into oncoming eyes. Both of these issues must be accomplished while putting as much light as possible on the road.

These fog weather light aiming instructions are suggestions taken from common practice and the S.A.E. standard J583. Some modifications to these instructions may be necessary to minimize glare.

Visual aim is made with the top of the beam 4 inches below the lamp center at 25 feet with the lamp facing straight forward (see picture 23)

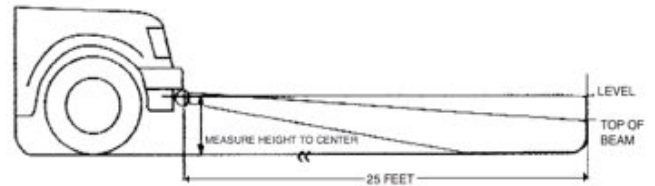

Picture 23

**Check**

Accessory Functions Checks

---

- Fog Lights function.....
- All Panels snapped into place.....
- Fog Lights.....
- Battery Terminal.....

Vehicle Function checks

---

- Check functions all switch functions

**Look For:**

---

Loose panels and switches

Visually confirm lights are straight forward

Re-torque battery terminals to 48 in-lb

Place fog light operation guide inside glove box.

**VEHICLE FUNCTION CHECK**

AFTER ALL PANELS, COVERS AND COMPONENTS THAT WERE REMOVED HAVE BEEN REINSTALLED, TEST THOROUGHLY ALL MECHANICAL AND ELECTRICAL COMPONENTS DISCONNECTED AND/OR REMOVED FROM THE VEHICLE DURING THE INSTALLATION OF THIS ACCESSORY

# Block Diagram Fog Lights

Sienna 2016

Rev. 10-27-2014

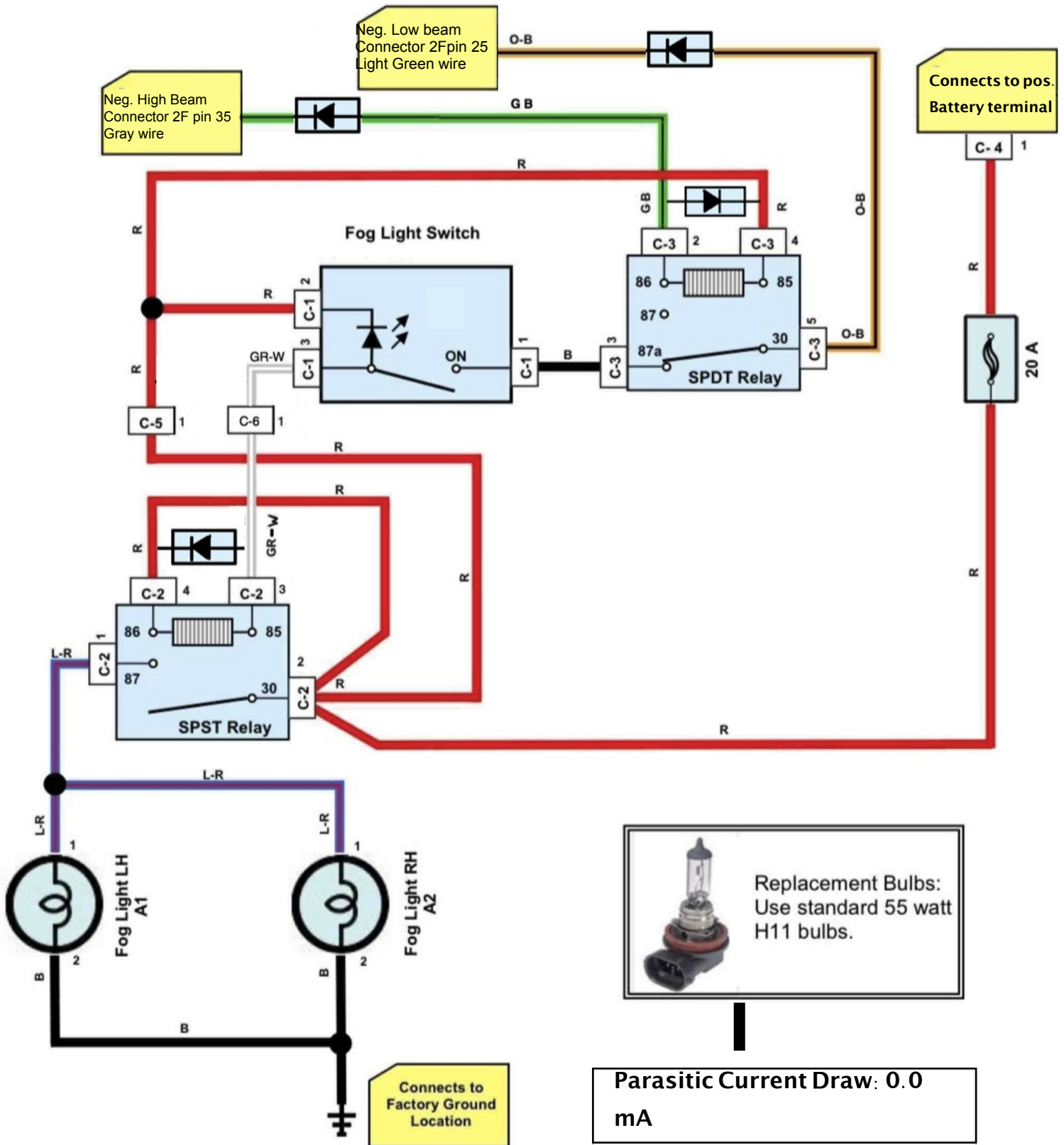

# Pinout test

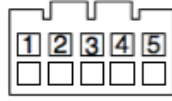

## Connector C-1

**\*\* Unplug connector from switch prior to testing pin outs**

Pin	Wire Color	Test Reference	Proper Operation
1	Black	Pin 1 to Ground	Aprox. +12 VDC when headlights are OFF or HIGH BEAMS ON 0 VDC when headlights are ON (LOW BEAM position)
2	Red	Pin 2 to Ground	Always +12 VDC
3	Gray - White	Pin 3 to Ground	Approximately +12 VDC when FOG LIGHT switch is OFF Approximately +12 VDC when headlights are OFF or HIGH BEAMS ON 0 VDC with FOG LIGHT switch ON and headlights are ON (LOW BEAM position)

## Connector C-2,

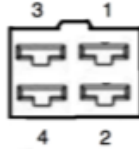

FEMALE TERMINALS (TERMINAL VIEW)

**\*\*Leave Relay connected while testing the pinouts**

Pin	Wire Color	Test Reference	Proper Operation
1	Blue - Red	Pin 1 to Ground	Approximately 0 VDC when FOG LIGHT switch is OFF Approximately 0 VDC when headlights are OFF or HIGH BEAMS ON +12 VDC with FOG LIGHT switch ON and headlights are ON (LOW BEAM position)
2	Red	Pin 2 to Ground	Always + 12 VDC
3	Gray -White	Pin 3 to Ground	Approximately +12 VDC when FOG LIGHT switch is OFF Approximately +12 VDC when headlights are OFF or HIGH BEAMS ON 0 VDC with FOG LIGHT switch ON and headlights are ON (LOW BEAM position)
4	Red	Pin 4 to Ground	Always + 12 VDC

## Connector C-3

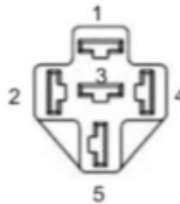

FEMALE TERMINALS  
TERMINAL VIEW

**\*\*Leave Relay connected while testing the pinouts**

Pin	Wire Color	Test Reference	Proper Operation
2	Green - Black	Pin 2 to Ground	Aproximately 0 VDC when High beam switch is ON +12 VDC All other times
3	Black	Pin 3 to Ground	Aprox. +12 VDC when headlights are OFF or HIGH BEAMS ON 0 VDC when headlights are ON (LOW BEAM position)
4	Red	Pin 4 to Ground	Always +12 VDC
5	Orange-Black	Pin 5 to ground	Approximately +12 VDC when headlights are OFF or HIGH BEAMS ON 0 VDC when headlights are ON (LOW BEAM position)

### Connector C-4



Pin	Wire Color	Test Reference	Proper Operation
1	Red	Pin 1 to Ground	Always +12 VDC

### Connector C-5



**\*\* Leave connectors connected white testing pin outs**

Pin	Wire Color	Test Reference	Proper Operation
1	Red	Connector to Ground	Always +12 VDC

### Connector C-6



**\*\* Leave connectors connected whi**

Pin	Wire Color	Test Reference	Proper Operation
1	Gray - White	Connector to Ground	Approximately +12 VDC when FOG LIGHT switch is OFF Approximately +12 VDC when headlights are OFF or HIGH BEAMS ON 0 VDC with FOG LIGHT switch ON and headlights are ON (LOW BEAM position)

### Connectors A-1, A-2

Fog Lamp connector at Bulb



FEMALE TERMINALS  
TERMINAL VIEW  
HARNES SIDE

Pin	Wire Color	Test Reference	Proper Operation
1	Blue Red	Pin 1 to Ground	Approximately 0 VDC when FOG LIGHT switch is OFF Approximately 0 VDC when headlights are OFF or HIGH BEAMS ON +12 VDC with FOG LIGHT switch ON and headlights are ON (LOW BEAM position)
2	Black	Pin 2 to Ground	Always continuity